

USER MANUAL

NTN-SNR SELF-CENTER MECHANICAL PULLERS Tool SCMP 2/3 series



Read instructions and follow carefully before using pullers

1. INTRODUCTION

These self-centering mechanical pullers are meant for dismantling of all kinds of shaft fitted parts.

Operating conditions

To be used in industrial environment

User requirements

This person should have basic technical knowledge. Only trained personnel should use these pullers.

Principle operation

The puller jaws grip around the part after which the push adapter is jacked from the centre of the shaft.

2. SAFETY PRECAUTIONS

! WARNING: prevent personal injury

- Select the proper size and capacity of puller for the job. This is determined by measuring “reach” and “spread” of the part to be pulled.
- Align the puller on the same centerline as the part being removed. Failure to align parts correctly can result in a dangerous operating situation.
- Wrap the work in a protective blanket before applying pressure to provide protection from injury caused by flying parts should a part ever break.
- Safety glasses must be worn at all times by the operator and anyone within sight of the puller.
- Always apply force gradually.
- Never heat the part to be removed when connected with the puller. Heating can result in damage of the puller.

3. PULLER SETUP AND OPERATION

Note: These pullers have a 2/3-way combination puller head. The 3-jaw combination is strongly recommended whenever the job space allows for it. Three jaws give a more secure grip and more even pulling force.

- Inspect pullers on arrival. Notify NTN-SNR if shipment is not in good order.
- Select the proper size and capacity of puller needed for the job. This is determined by measuring “reach” and “spread” of the part to be pulled.

Figure 1:

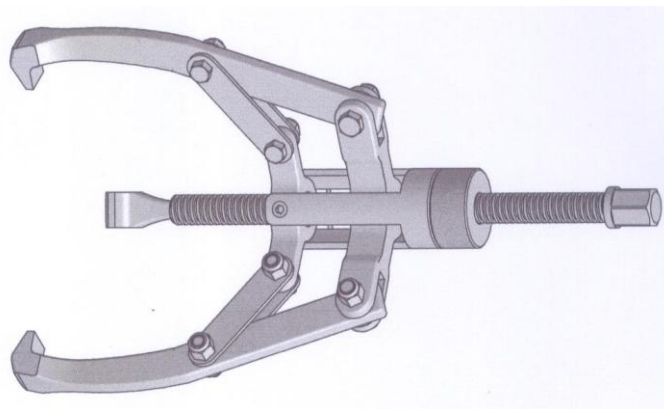

- Begin positioning the puller and puller jaws by turning the control nut in clockwise direction to close the jaws around the parts to be pulled.

Figure 2:

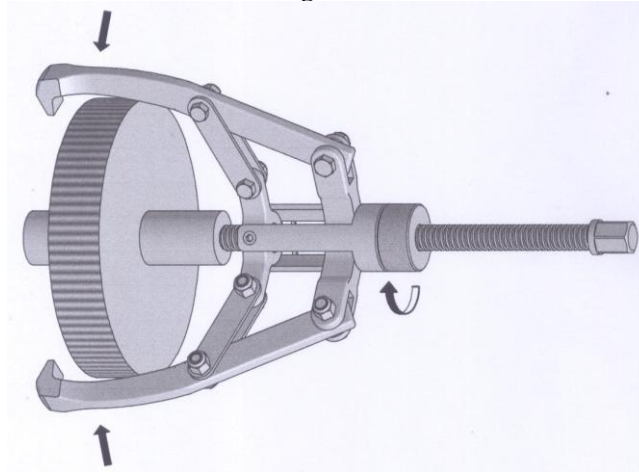

! WARNING: The adjusting lock nut must be fully engaged with the threads of the puller body.

- Position the jaws around the part to be pulled.
- Tighten the nut so that arms remain in place.
- Check and make final adjustments. The puller must be in the same centre line as the part to be pulled, jaws fully engaged and secure.

Figure 3

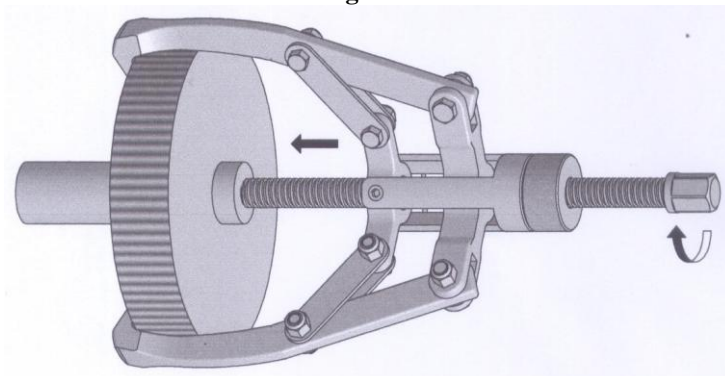

- Wrap safety blanket around the puller and part.
- Hold the puller with one hand and turn the main spindle with a T-wrench with the other hand, advancing the main shaft until the part is removed.

4. PARTS LIST

Ref. No.	Description
01	Threaded Spindle Shaft
02	Spindle Shaft
03	Guide Socket
04	Main 2/3 way Cross head
05	Puller Jaw
06	Jaw Upper Bolt & Nut
07	Jaw Strap
08	2/3 way Sliding Cross Head
09	Head Bolt & Nut
10	Jaw Bolt & Nut
11	Retaining Screw

